

Supplemental Operating Instructions

IS450DE VRS



Image Scanner

Copyright

Copyright © 2000 Kofax Image Products. All Rights Reserved. Printed in the USA.
Copyright © 2000 Ricoh Corporation. All Rights Reserved.

The information contained in this document is the property of Kofax Image Products. Neither receipt nor possession hereof confers or transfers any right to reproduce or disclose any part of the contents hereof, without the prior written consent of Kofax Image Products. No patent liability is assumed, however, with respect to the use of the information contained herein.

Trademarks

Kofax, ImageControls, and Adrenaline are registered trademarks and VirtualReScan is a trademark of Kofax Image Products.

All other product names and logos mentioned herein are the property of their respective companies.

Disclaimer

The instructions and descriptions contained in this document were accurate at the time of printing. However, succeeding products and documents are subject to change without notice. Therefore, Kofax Image Products assumes no liability for damages incurred directly or indirectly from errors, omissions, or discrepancies between the product and this document.

An attempt has been made to state all allowable values where applicable throughout this document. Any values or parameters used beyond those stated may have unpredictable results.

Contents

Introduction.....	1
Product Overview.....	1
VRS Product Package.....	2
System Requirements.....	2
PC.....	2
Scanner.....	2
Installation.....	3
Step 1. Install the Software.....	3
Step 2. Install the Adrenaline Hardware Accelerator.....	5
Compatibility with Current Accelerators and Engines.....	5
Precautions.....	5
Connect PC to Scanner.....	6
Configure the Accelerator - Windows 95.....	6
Configure the Accelerator - Windows NT.....	7
Step 3. Attach Your Scanner.....	8
Starting VirtualReScan.....	9
Opening the VRS Menu.....	10
First Time Calibration.....	10
VRS Menu Commands.....	13
Defining Exception Conditions.....	14
Warnings Tab.....	14
Selecting the Threshold.....	15
Selecting an Action.....	16
Errors Tab.....	16
Action Options.....	17
Using the Auto Resolve Manager.....	19
Selecting a Mode.....	20
Updating Image Properties.....	21
Using the VRS Viewer.....	22
Using the Zoom Menu to adjust the view.....	22
Using mouse buttons to adjust the view.....	22
Using the VRS Interactive Properties Dialog Box.....	23
VRS Interactive Properties Dialog Box Tabs.....	23
VRS Interactive Properties Dialog Box Buttons.....	24
Using the Clarity Tab.....	25
Using the Noise Tab.....	27
Using the Skew Tab.....	29

Using the Profiles Tab	31
Using the Options Tab	33
VRS Refresh	34
Intelligent Contrast Adjustment / Brightness Adjustment	34
Using the Analysis Tab	35
Using the About Tab	36
Previewing Images	37
Resetting VRS	38
Technical Support	39

Introduction

This guide gives you instructions for installing the hardware and software components of VirtualReScan (VRS).

Product Overview

VRS makes high-volume scanning easier and more cost-effective than ever. With automatic detection of poor image quality, VRS performs automatic image enhancements that greatly reduce recognition errors. To ensure that every scanned image can meet your standards, VRS provides an interactive settings control that eliminates the guesswork with easy, real-time image correction.

Other features include the ability to scan batches that consist of multiple document sizes or varying degrees of quality, as well as the ability to automatically assign contrast and brightness settings that are optimal for your document type. If specified, VRS can even remove color that may interfere with the data you are collecting. VRS will also detect paper jams, bent corners, and equipment conflicts. It is no longer necessary to pre-sort mixed batches, and in addition to the time savings, post-processing accuracy is increased and storage requirements are reduced.

For batch scans in which Optical Character Recognition (OCR) precision is crucial, as it is for database-bound information, low-contrast documents traditionally pose significant problems. With VRS, you can enable "Intelligent Contrast / Brightness Adjustment" and process the batch with confidence, knowing that every low-contrast image will be adjusted automatically to the acceptable level of quality required for OCR.

In addition to Intelligent Contrast / Brightness Adjustment, VRS offers a range of features to help you ensure the highest level of quality for every scanned image:

- Automatic Deskew Correction
- Image Cropping
- Accelerated Scanning
- Despeckling
- Gamma Correction
- Character Smoothing
- Character Dilation/Erosion

VRS Product Package

Your VRS product package includes the following items:

- VRS installation CD
- Scanner cable
- *VirtualReScan Getting Started Guide*

System Requirements

Be sure that your PC and scanner meet the following requirements:

PC

- Pentium II class PC with a 200 Mhz processor, or greater
Pentium II class PC with a 400 Mhz or greater (grayscale scanning)
- 64 Mbytes RAM
128 Mbytes RAM (grayscale scanning)
- Windows 95 or Windows NT 4.0 with 32-bit support
- Hard drive with 200 Mbytes free disk space
- Monitor resolution: 800 x 600 minimum; 1024 x 768 recommended
- Adrenaline 850v Hardware Accelerator (sold separately)

Scanner

- Ricoh Model IS450DE/V

Installation

This section explains how to install the hardware and software required to run VRS. The installation process consists of three basic steps:

- 1 Install the VRS software on your PC.
- 2 Install the Adrenaline Hardware Accelerator in your PC.
- 3 Attach the scanner to your PC.

Step 1. Install the Software

This section explains how to install the VirtualReScan software. The default installation folder is C:\ProgramFiles\Kofax\Imgctl, although you can install to another folder. To install VRS under Windows NT, you must have administrator rights.

If an earlier version of Kofax ImageControls® exists on your computer, you can upgrade it by completing the installation procedure in this section.

► To install the VRS software

- 1 Verify that the VRS installation CD is inserted in the appropriate CD-ROM drive.
- 2 Select Start | Run and do one of the following to select the path for the setup file on the VRS installation CD. Select the path as D:\Setup.Exe, where D: is the CD-ROM drive:
 - a Use the Browse button to select the path.
 - b In the text box, type in the path.
- 3 Click OK.

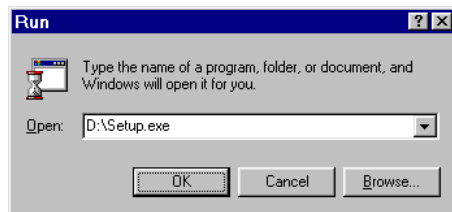

Figure 1. VRS Installation Program Path

The VirtualReScan Setup dialog box opens, as shown in Figure 2.

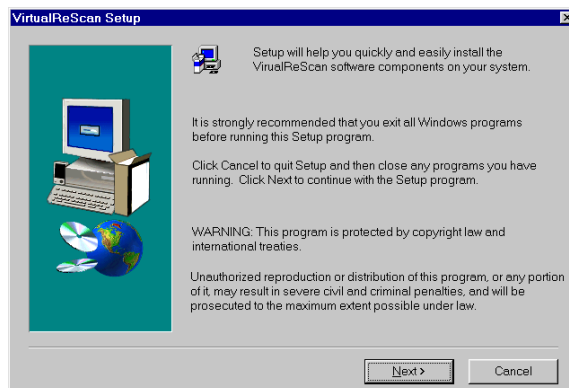

Figure 2. VirtualReScan Setup Dialog Box

- 4 Click Next to open the next VirtualReScan Setup dialog box, similar to Figure 3. Verify that VirtualReScan is selected, along with the correct installation folder. The default folder is C:\Program Files\Kofax\Imgctls. If desired, use the Browse button to select another installation folder.

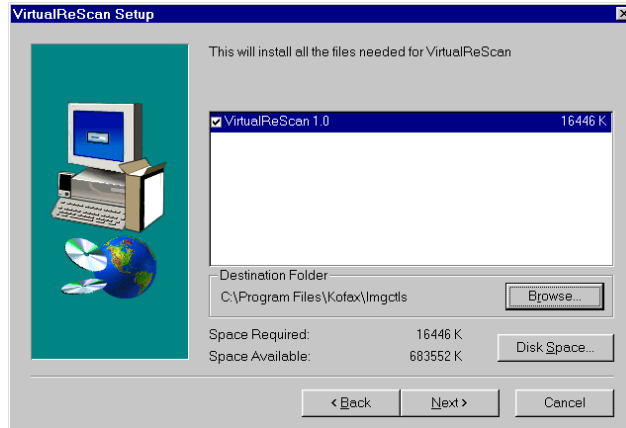

Figure 3. VirtualReScan Setup Dialog Box 2

- 5 Click Next. The installation begins, and a progress indicator stays in view until the process is done. When the VRS installation finishes, the Setup Complete dialog box displays, similar to Figure 4.

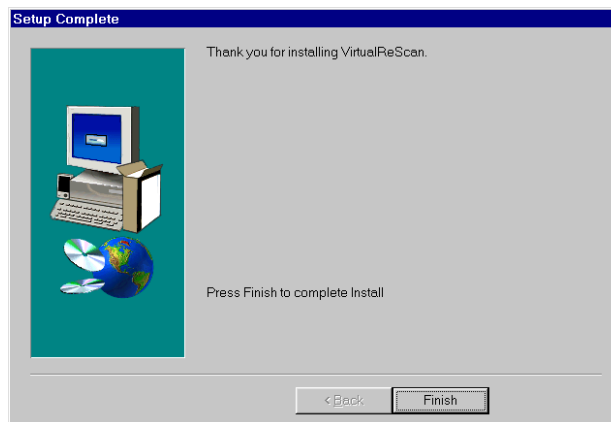

Figure 4. Setup Complete Dialog Box

- 6 Select the option to restart your computer immediately, or to restart it later, and click Finish.

Note: It is important to restart the computer to ensure that Windows recognizes the drivers required for the Adrenaline Hardware Accelerator.

- 7 Remove the VRS installation CD from the CD-ROM drive and store it in a safe place.

Step 2. Install the Adrenaline Hardware Accelerator

This section explains how to install the Adrenaline Hardware Accelerator.

Note: To run VirtualReScan successfully, you need to install only the software provided on the VRS installation CD. **Do not** install the software provided on the Adrenaline Hardware Accelerator CD.

Compatibility with Current Accelerators and Engines

We recommend that you install the Adrenaline Hardware Accelerator on a PC with no other Kofax hardware accelerators. If necessary, remove the older Kofax accelerators before you install the Adrenaline Hardware Accelerator.

Precautions

When handling your Adrenaline Hardware Accelerator, follow these precautions:

- Keep the accelerator in its original shipping package until you are ready to install it.
- Power off your PC before installing the accelerator.
- Before handling the accelerator, discharge static electricity from yourself and the work area by touching the metal chassis of the PC.
- Hold the accelerator by the edges; do not touch its metal surface.

Before installing the accelerator, make sure your PC is powered off. Then, install the accelerator in any available PCI slot. Be sure to use the screws to secure it into place.

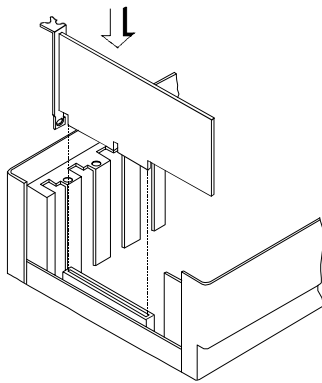
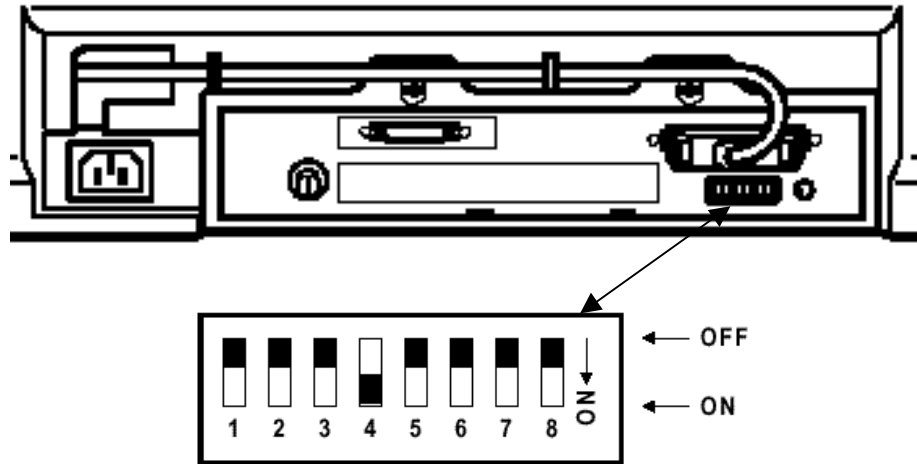

Figure 5. Installing an Adrenaline Hardware Accelerator in Your PC

Connect PC to Scanner

Make sure switch 4 is down.

NOTE: Verify that the Dip Switches at the back of the “Scanner Control Unit” are in the configuration illustrated below.



Configure the Accelerator - Windows 95

After installing the Adrenaline Hardware Accelerator, power on your PC. Windows detects the Adrenaline Hardware Accelerator, and if you have successfully installed the VRS software, it automatically locates the drivers required by the accelerator.

Configure the Accelerator - Windows NT

After successful installation of the software, an item for the Kofax Configuration Manager utility is added to your Windows | Control Panel folder.

► To configure your Adrenaline Hardware Accelerator under Windows NT

- 1 Select Settings | Control Panel | Kofax Configuration Manager. The following dialog box opens:



Figure 6. Kofax Configuration Manager (KCM) Dialog Box

Note: If your Control Panel does not include the Kofax Configuration Manager utility, the software installation was not successful.

- 2 Click Next. A dialog box opens, similar to Figure 7:

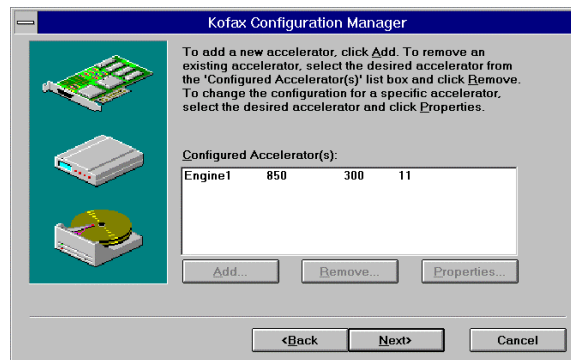

Figure 7. KCM Configured Accelerators Dialog Box

- 3 Click Next and follow the instructions on your screen to finish the installation. If prompted to do so, reboot your PC.

Step 3. Attach Your Scanner

When you remove the cable from your product package, notice that one connector is marked *Kofax* and the other is marked *Scanner*. The Kofax connector attaches to the PC, and the Scanner connector attaches to the scanner.

► **To connect the scanner to your PC**

- 1 Attach the cable connector marked Kofax to the connector on the Kofax Adrenaline Hardware Accelerator in your PC.
- 2 Attach the cable connector marked Scanner to the matching port on the scanner.

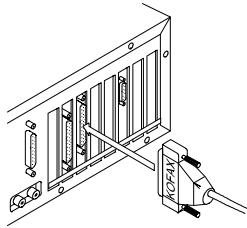

Attach the Kofax connector (Step 1)

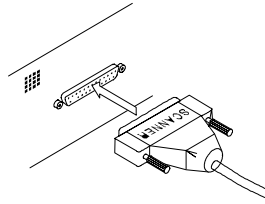

Attach the Scanner connector (Step 2)

Figure 8. Connecting the Scanner to Your PC

Starting VirtualReScan

Once the installation is complete, activate VRS by selecting the VirtualReScan Source from your scanning application. Once you select the source, the VRS icon appears on the Windows taskbar to signal that VRS is active.

Note: During the VRS installation process, the VirtualReScan Source is automatically created and set as the default scanning source. If you have questions about how to select the source from your scanning application, consult with your system administrator.

► **To start VRS**

- 1 Power on your scanner.
- 2 Start your scanning application and select the VirtualReScan Source.
- 3 The VRS icon appears on your Windows taskbar, similar to Figure 9.



Figure 9. VRS Icon

Opening the VRS Menu

You can open the VRS menu to configure exception condition parameters, preview and update image properties, select a profile or operating mode, or to reset the Adrenaline Hardware Accelerator in your PC.

► **To open the VRS menu**

- 1 From the Windows taskbar, right-click on the VirtualReScan icon to open the VRS menu.



Figure 10. VRS Menu

- 2 When using VRS the first time, begin by selecting the Configure command. For more information, see the section *Defining Exception Conditions* on page 14. For information on other menu options, see the next section, *VRS Menu Commands*.

First Time Calibration

NOTE: This procedure can be repeated if the preview of the scanned original degrades.

Start Program from Icon on desktop, Double Click VCDemo32.EXE, Maximize

1. Select **Source, Scanner** from pull-down menus

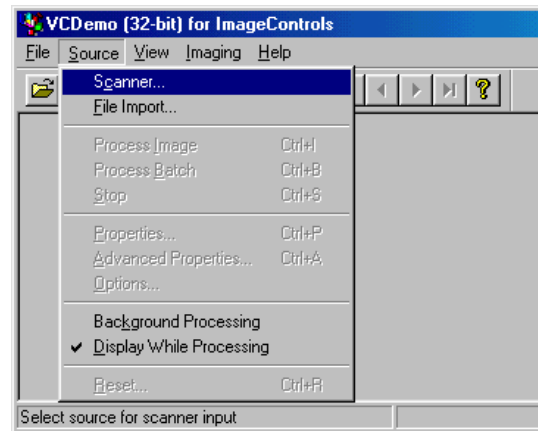

2. Select **Ricoh VirtualReScan Source Calibration** from pull-down menu, then click on **OK**

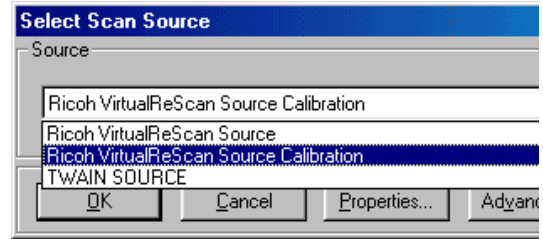

3. Select **Source, Properties**

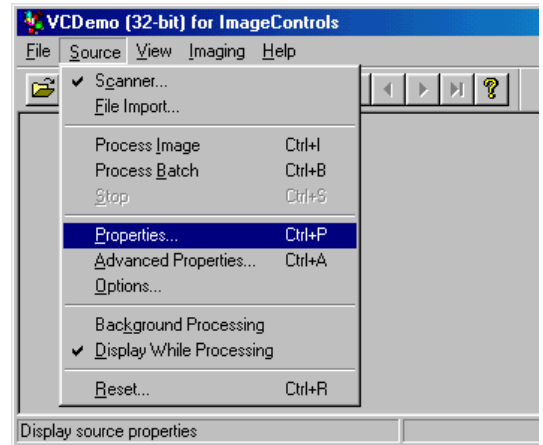

4. Verify that the settings are as follows, ADF, 200DPI, Maximum Page Size, Duplex, click on **OK**

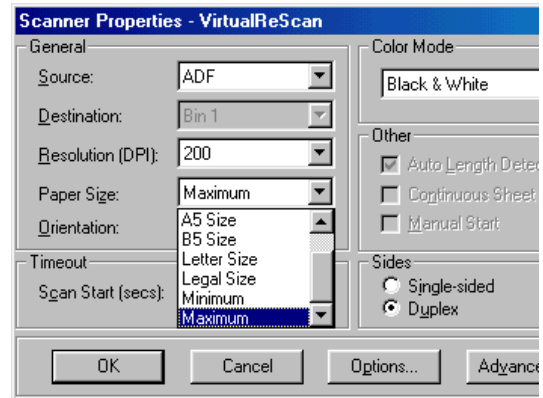

5. Place the 12"by 12" Calibration Sheet in ADF.

The Document Guides should be at maximum width.

Click on the **Scan Page** Tool from the Toolbar to scan and calibrate first image.



- If Calibration is successful, the display windows will be visible as in the example to the right.

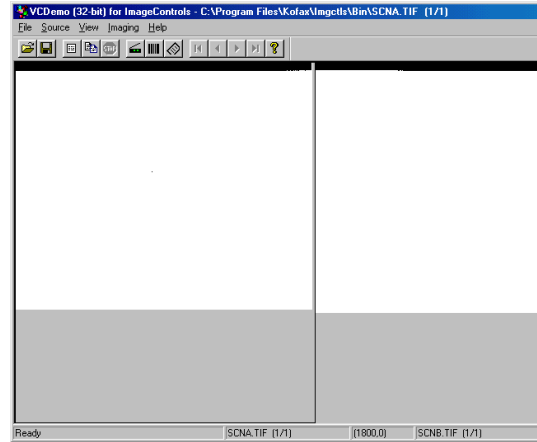

- Select **Source, Scanner** from the pull-down menu in preparation for an ADF scan.

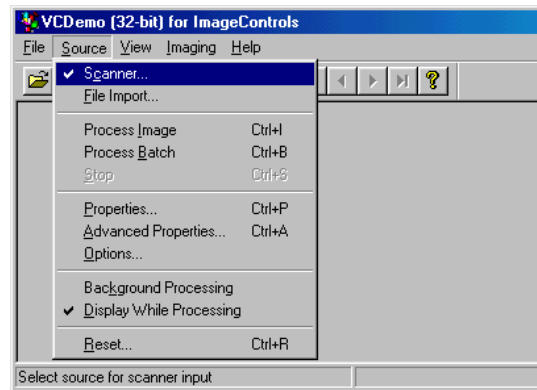

- A Window will display stating that the source is already in use, click on **Yes** to change.

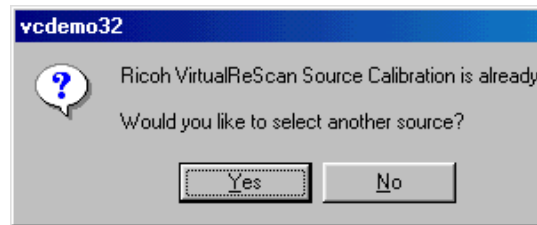

- Select **Ricoh VirtualReScan Source**, then click on **OK**.

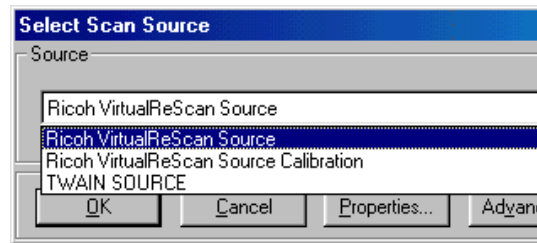

10. Engine Load Window will display and disappear when successfully loaded.

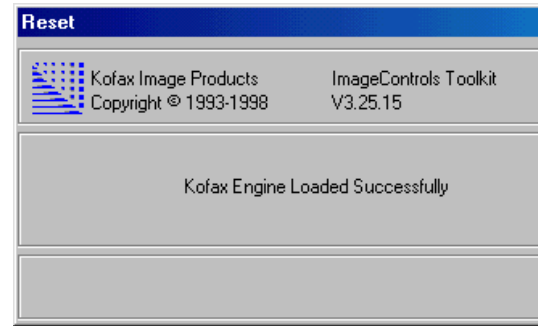

VRS Menu Commands

The VRS menu consists of the following commands:

Preview

Use this command to open a sample image, so that you can test image property settings. For more information, see the section *Previewing Images* on page 37.

Profile

Use this command to select a profile, which consists of user-defined settings for image processing. For more information about profiles, see the section *Using the Profiles Tab* on page 31.

Mode

Use this command to select an operating mode, which determines the conditions under which the VRS user interface opens during a scanning session. For more information, see the section *Selecting a Mode* on page 20.

Configure

Use this command to open the VRS Administration Utility dialog box, which is used to define exception condition parameters. For more information, see the section *Defining Exception Conditions* on page 14.

Reset

Use this command if you are instructed by authorized technical support personnel to reset the configuration for the Adrenaline Hardware Accelerator. For more information, see the section *Resetting VRS* on page 38.

Defining Exception Conditions

Before scanning, set up parameters that define your requirements for image quality and exception handling. To set the parameters, open the VRS Administration Utility dialog box by selecting the Configure command from the VRS menu.

The VRS Administration Utility dialog box consists of dual tabs relating to two exception types. The Warnings tab relates to image quality issues, and the Errors tab relates to equipment conflicts and paper transport issues. For each tab, you define settings that tell VRS exactly how to respond when it detects an exception image, an equipment conflict, or a paper transport issue. You can use the default settings on the Warnings and Errors tabs, or customize how VRS handles each exception type. The settings on the VRS Administration Utility dialog box remain in effect until you change them again.

For detailed information on changing the settings, see the sections *Warnings Tab* on page 14 and *Errors Tab* on page 16.

Warnings Tab

The Warnings tab lists exception conditions associated with image quality. For each condition, set a threshold value to the level at which you want VRS to consider an image as an exception. In the Action column, select the response to each warning type.

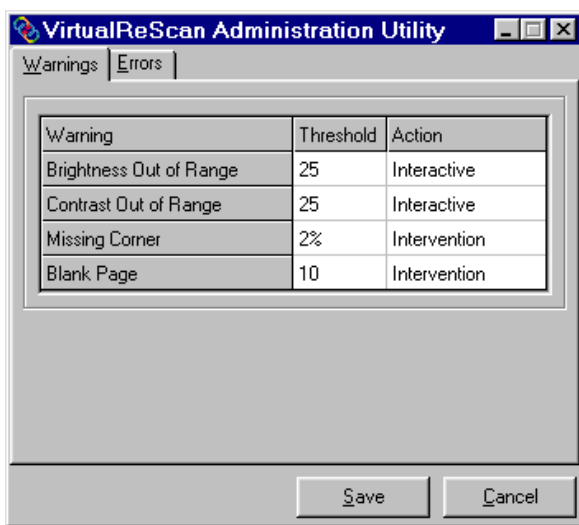

Figure 11. VRS Administration Utility Dialog Box - Warnings Tab

Table 1. Warning Types

Warning	Cause
Brightness Out of Range	Brightness value for the image falls outside the acceptable range.
Contrast Out of Range	Contrast value for the image falls outside the acceptable range.
Missing Corner	Scanned image includes a missing or obscured corner.
Blank Page	Scanned image is blank, or it contains a limited amount of data.

Selecting the Threshold

The threshold defines the "margin of error" that VRS tolerates for brightness, contrast, missing corners and blank pages. VRS intercepts any image with values that fall outside the margin of error. VRS handles the image according to the action you define for each exception type.

Brightness Out of Range Threshold

Use the threshold to define the valid range for brightness values. When a document is scanned, VRS evaluates the resulting image to determine its brightness. Then, VRS compares it to the user-defined brightness value set in the Clarity tab. Concurrently, VRS also identifies the user-defined acceptable value in the Brightness Out of Range setting in the Warnings tab. Based on this real-time evaluation, VRS either accepts the image and allows it to be passed on to the scanning application, or intercepts it and responds according to the user-defined action in the Warnings tab.

For example, if the brightness value on the Clarity tab is 50, and the threshold is 10 on the Warnings tab, VRS accepts any image with a detected brightness value ranging from 40 to 60. The range starts at 40, which is 10 less than 50, and it ends at 60, which is 10 more than 50. Therefore, an image with a brightness value of 70 would fall outside the valid range. VRS would respond by taking the action listed on the Warnings tab for Brightness Out of Range.

Contrast Out of Range Threshold

Use the threshold to define the valid range for contrast values. When a document is scanned, VRS evaluates the resulting image to determine its contrast. Then, VRS compares it to the user-defined contrast value set in the Clarity tab. Concurrently, VRS also identifies the user-defined acceptable value in the Contrast Out of Range setting in the Warnings tab. Based on this real-time evaluation, VRS either accepts the image and allows it to be passed on to the scanning application, or intercepts it and responds according to the user-defined action in the Warnings tab.

For example, if the contrast value on the Clarity tab is 65, and the threshold is 15 on the Warnings tab, VRS accepts any image with a contrast value ranging from 50 to 80. The range starts at 50, which is 15 less than 65, and it ends at 80, which is 15 more than 65. Therefore, an image with a contrast value of 40 would fall outside the valid range and generate a warning. VRS would respond by taking the action listed on the Warnings tab for Brightness Out of Range.

Missing Corner Threshold

Use the threshold value to define the level at which a missing or obscured corner should be considered as an exception. The threshold is a percentage that represents the amount of the document width that is allowed to be obscured or missing. For example, if you scan a document with a one-half inch fold in the upper right corner, the missing section would translate to almost 6% (for a standard 8½ x 11 sheet). If you define the threshold for Missing Corner as 7%, VRS would process the document without issuing a warning. If you define the threshold as 5%, VRS would generate a warning and take the action listed on the Warnings tab for Missing Corner.

Blank Page Threshold

Use the threshold to define the level at which lack of data is sufficient to constitute a Blank Page warning. The range for the Blank Page threshold is 0 to 10, with a setting of 0 representing strict criteria that requires a blank page to be totally blank. A setting of 10 offers more flexibility, allowing blank pages to include documents with a limited degree of data, such as smudges or shadow-generated data. If necessary, adjust the threshold setting to suit your document type.

Note: You may need to adjust the Blank Page threshold setting according to the color of the document. For example, a threshold that successfully detects a white blank page may not detect a dark green blank page. If you plan to scan colored documents, it is a good idea to scan a sample of each color to test the Blank Page threshold setting.

Selecting an Action

When a warning condition occurs, VRS handles it according to the Action setting you select. For details on selecting an action type, see the section *Action Options* on page 17.

Errors Tab

The Errors tab lists exception conditions caused by equipment conflicts or paper transport issues, as well as one condition caused by inability to detect document edges. In the Action column, select the desired VRS response for each error type. To change the setting, click in the Action box and select from the drop-down list. For details, see *Action Options* on page 17.

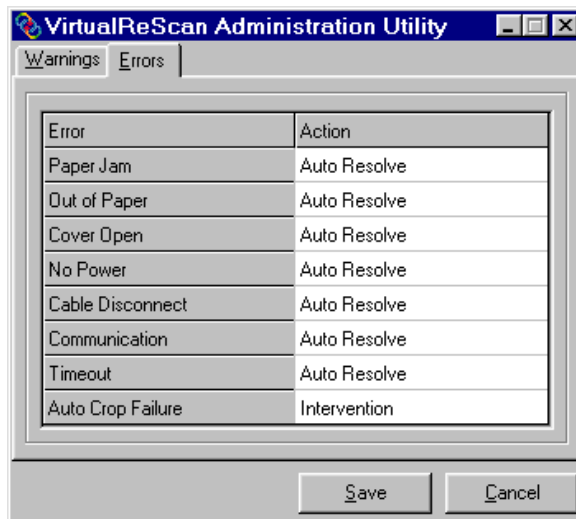

Figure 12. VRS Administration Utility - Errors Tab

Table 2. Error Types

Error	Description
Paper Jam	Paper jam occurs in the scanner paper path.
Out of Paper*	No paper is available to scan.
Cover Open	Scanner cover is not closed securely.
No Power	Power is off, or power cable connection is loose.
Cable Disconnect	Scanner cable is not attached properly to the scanner or to the Adrenaline Hardware Accelerator in the PC.
Communication	Communication conflict exists between the scanner and the PC.
Timeout	Scanner is unable to respond within the predefined period of time.
Auto Crop Failure	Due to excessive skew or other condition, VRS is unable to detect the edges of the scanned document.

*With some ISIS scanning applications, VRS does not generate an error for an out of paper condition.

Action Options

Use the Action box to define how you want VRS to handle each exception condition listed on the Warnings tab and the Errors tab. To define an exception action type, click in the Action box on the Warnings tab or the Errors tab, and select from the drop-down list. The action options vary, according to the type of warning or error.

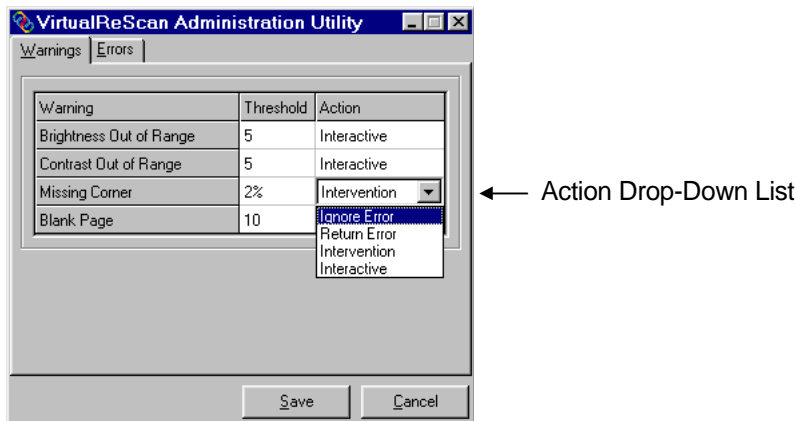

Figure 13. Action Drop-Down List

Table 3. Action Types

Action Type	Description
Return Error	Pass error (without the image) to the host application.
Ignore Error	Accept image "as is," pass it to the host application, and resume the scanning session.
Intervention	Open the Auto Resolve Manager in manual mode. As a result, the user is presented a range of options for handling the error. See the next section, <i>Using the Auto Resolve Manager</i> .
Auto Resolve	Opens the Auto Resolve Manager in automatic mode. As a result, the scanner automatically attempts to retry the scan until the user resolves an equipment or paper transport impediment, such as a loose cable, paper jam, or out of paper condition. See the next section, <i>Using the Auto Resolve Manager</i> .
Interactive	Opens the VRS Interactive Properties dialog box and displays the image in the VRS Viewer, so that the user can apply new settings to the current image. The dialog box opens to the tab that relates to the warning condition. For example, if a Brightness Out of Range warning occurs, the dialog box would open with the focus on the Clarity tab, where the brightness setting can be adjusted.

► **To define exception condition parameters**

- 1 From the Windows taskbar, right-click on the VRS icon to open the VRS menu.
- 2 From the VRS menu, select Configure to open the VRS Administration Utility dialog box.
- 3 Select one of the following tabs:
 - a Warnings tab

The Warnings tab gives you options to set the threshold and response for exceptions related to image quality, as listed in Table 1 on page 14.
 - b Errors tab

The Errors tab gives you options to set the response to exceptions related to equipment conflicts and paper transport errors, as listed in Table 2 on page 17.
- 4 Adjust the settings for each tab.
 - a Warnings tab - Threshold

From the Warnings tab, you can type directly into the Threshold box, or click the arrows to select a new threshold setting. For more information about thresholds, see the section *Warnings Tab* on page 14.
 - b Warnings tab/Errors tab - Action

From the Warnings tab and the Errors tab, define a VRS response to each exception type by clicking in the Action box and selecting from the drop-down list. For details, see *Action Options* on page 17.
- 5 Once you are satisfied with the settings, click Save.

Using the Auto Resolve Manager

VRS opens the Auto Resolve Manager dialog box for each occurrence of an exception condition with an Action type of Intervention or Auto Resolve, as defined in the VRS Administration Utility dialog box. The Auto Resolve Manager gives you a range of exception handling selections, as explained below.

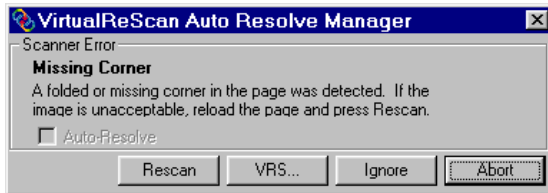

Figure 14. VRS Auto Resolve Manager

Auto Resolve check box

The check box is selected if you designated the error condition action response as *Auto Resolve* from the VRS Administration Utility dialog box. With the check box selected, the Auto Resolve Manager goes into automatic mode. As a result, VRS automatically attempts to rescan until the exception condition is resolved. If you want to temporarily disable the Auto Resolve function for the error in question, clear the check box. Then select the Rescan button when you are ready to scan the document again.

With the Auto Resolve check box cleared, the Auto Resolve Manager enters manual mode and enables the Rescan, VRS, and Ignore buttons. As a result, VRS takes no action until you select one of the buttons.

Rescan (manual mode only)

After reloading a document into the scanner, select this button to rescan the sheet.

VRS (manual mode only)

Use this button to open the VRS Interactive Properties dialog box, so that you can apply property changes to the image in question. The VRS Interactive Properties dialog box opens to the tab that most closely relates to the current exception image. For example, if you receive a Brightness Out of Range warning, the VRS Interactive Properties dialog box would open to the Clarity tab.

Ignore (manual mode only)

Use this button to accept the image "as is," send it to the scanning application, and proceed with the scanning process.

Abort

Use this button stop the batch or cancel the scanning process. When you select Abort, any error information is passed to your scanning application. The error image(s) are not sent to the scanning application.

Selecting a Mode

The Mode menu options control the conditions under which the VRS user interface opens for image inspection and interactive updates.

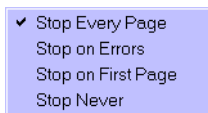

Figure 15. Mode Menu

By selecting the Mode command from the VRS menu, you can request that the VRS user interface display under the following conditions:

Stop Every Page

VRS dialogs open after each document scans; or with duplex scanning, after each document side scans.

Stop on Errors

VRS dialogs open only when exception conditions occur.

Stop on First Page

VRS dialogs open when you scan the first page of a batch and when exception conditions occur.

Stop Never

VRS dialogs remain out of view, even if exception conditions occur. In this case, any exceptions are passed to the scanning application (unless they are defined as *Ignore*).

After installation, the mode is set to Stop on Errors, which opens the VRS Viewer and the VRS Interactive Properties dialog box when an exception image is detected during the scanning process. Once you select a mode, it stays in effect until you change it again.

► **To change the mode**

- 1 From the Windows taskbar, right-click on the VRS icon to open the VRS menu.
- 2 From the VRS menu, select Mode.
- 3 From the Mode submenu, select an operating mode.

Updating Image Properties

While scanning, you can use VRS to apply property changes to images that are intercepted as exceptions. To update an exception image, use the VRS Interactive Properties dialog box to apply property changes to the image shown in the VRS Viewer.

The VRS Interactive Properties dialog box and the VRS Viewer open under the following circumstances:

- When VRS intercepts an exception image for which the response is defined as *Interactive*. See *Defining Exception Conditions* on page 14.
- As defined by the active operating mode. See *Selecting a Mode* on page 20.
- When you select the Preview feature. See *Previewing Images* on page 37.
- When you select the VRS button from the VRS Auto Resolve Manager. See *Using the Auto Resolve Manager* on page 19.

The VRS Viewer and the VRS Interactive Properties dialog boxes open together, as shown in Figure 16. You can use the VRS Interactive Properties dialog box to apply attribute changes to the image in the VRS Viewer.

For more information, see the next section, *Using the VRS Viewer*, as well as the section *Using the VRS Interactive Properties Dialog Box* on page 23.

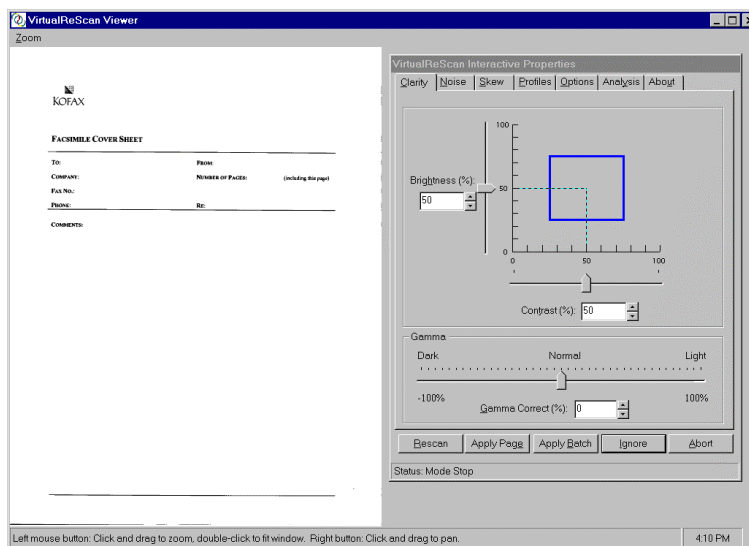

Figure 16. VRS Viewer with the VRS Interactive Properties Dialog Box

Using the VRS Viewer

The VRS Viewer displays scanned images for your inspection. The purpose of the Viewer is to show you what an image looks like when it scans, and to refresh the image as you apply property changes.

Note: To ensure that the VRS Viewer refreshes images as quickly as possible, you can enable the Accelerated VRS Refresh function from the Options tab. See the section *Using the Options Tab* on page 33.

The VRS Viewer includes a Zoom menu with a range of image magnification levels.

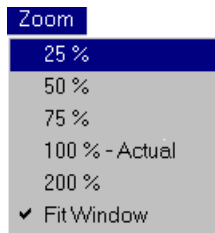

Figure 17. VRS Viewer Zoom Menu

Using the Zoom Menu to adjust the view

From the Zoom menu, you can select a setting to magnify or reduce the image in the Viewer. Using the Fit Window setting, you can view the entire image in the VRS Viewer.

Using mouse buttons to adjust the view

In the VRS Viewer, you can adjust the image view with the left and right mouse buttons.

Using the left mouse button, you can do the following:

- View part of the image by clicking and dragging a box to outline the section you want to magnify.
- Restore the image to the standard view by double-clicking.

Using the right mouse button, you can move (or pan) the image position in the VRS Viewer.

Using the VRS Interactive Properties Dialog Box

The VRS Interactive Properties dialog box consists of seven tabs, including four with options for dynamically adjusting image properties as you scan. The tabs are shown in Figure 18.

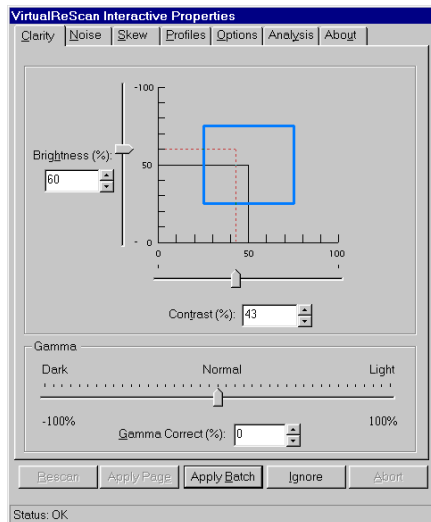

Figure 18. VRS Interactive Properties Dialog Box

When the dialog box opens for an exception condition, the status line lists the specific cause for the warning or error. Otherwise, you see "Status OK" on the status line. The dialog box opens to the tab that is relevant to the current warning or error condition. For example, if the warning is caused by a Brightness Out of Range condition, the VRS Interactive Properties dialog box opens to the Clarity tab. From the Clarity tab, you could make adjustments to resolve the condition.

VRS Interactive Properties Dialog Box Tabs

The VRS Interactive Properties dialog box consists of the following tabs:

Clarity

Use this tab to adjust the settings for brightness, contrast and gamma correction. For details, see the section *Using the Clarity Tab* on page 25.

Noise

Use this tab to select image enhancement filters, to apply character erosion/dilation, or to remove unwanted speckling from an image. For details, see the section *Using the Noise Tab* on page 27.

Skew

Use this tab to straighten an image that is skewed, or crooked. Settings on the Skew tab apply only to the current image in the VRS Viewer window. For details, see the section *Using the Skew Tab* on page 29.

Profiles

Use this tab to create and manage image property profiles. A profile consists of user-defined settings from the Clarity, Noise, and Options tabs in the VRS Interactive Properties dialog box. For details, see the section *Using the Profiles Tab* on page 31.

Options

Use this tab to activate optional features, such as Automatic Deskew, Image Crop, Accelerated Scanning, and VRS Refresh. For details, see the section *Using the Options Tab* on page 33.

Analysis

Use this tab to view a summary of the property settings for the most recently scanned image. For details, see the section *Using the Analysis Tab* on page 35.

About

Use this tab to view information about your VRS software version, as well as the street address, telephone and fax numbers, web site address, and e-mail address for Kofax Image Products. Additionally, the VRS Online button gives you direct access to the VirtualReScan web site, which offers product information and instructions for downloading VRS product updates. For details, see the section *Using the About Tab* on page 36.

VRS Interactive Properties Dialog Box Buttons

The following buttons are available when you use the VRS Interactive Properties dialog box. Keep in mind that the button selection applies to the entire set of dialog box tabs, including the active tab. When you change the settings on the VRS Interactive Properties dialog box, they remain in effect until you close VRS. When VRS restarts, the dialog box is reset to the default settings.

Rescan

After reloading a document into the scanner, select this button when you are ready to send the sheet through the scanner again. If you are using an automatic document feeder (ADF), you need to reload the document into the scanner ADF.

Apply Page

Use this button to apply the current settings to the image in the VRS Viewer. With this selection, the settings do not stay in effect for subsequent scanned images.

Apply Batch

Use this button to apply the current dialog box settings to the image in the VRS Viewer window, and to keep the settings in effect for future batches.

Ignore

Use this button to indicate that VRS should accept an image "as is." As a result, VRS ignores a warning/error condition and resumes the scanning session. Additionally, VRS abandons any changes, and restores the settings that were in effect when the dialog box first opened.

Abort

Use this button to stop the batch and close the VirtualReScan Interactive Properties dialog box without applying or saving any changes. When you select Abort, VRS passes any errors to the scanning application. Error images are not sent to the scanning application.

Using the Clarity Tab

The Clarity tab provides options to adjust the contrast, brightness, and gamma correction for an image. Contrast relates to the range of the lightest and darkest shades in an image. Brightness relates to the intensity (or density) of the gray shades in an image. Gamma relates to the contrast between the light and dark areas of an image.

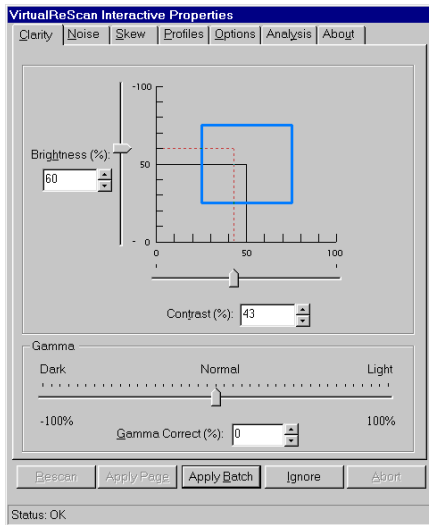

Figure 19. Clarity Tab

Brightness and Contrast

You can set the values for contrast and brightness yourself, or opt to have VRS automatically assign optimal values for contrast and brightness. To enable VRS-assigned values, select Intelligent Contrast Adjustment/Brightness Adjustment from the Options tab. See the section *Using the Options Tab* on page 33.

When VRS checks the validity of the brightness and contrast values for a scanned image, it checks the Clarity tab settings and the VRS Administration Utility - Warnings tab settings. For example, if the image brightness value matches the brightness setting on the Clarity tab, or falls within the range defined by the Brightness Out of Range threshold on the Warnings tab, it is acceptable. If the image brightness value does not fall within the acceptable range, VRS intercepts the image.

To illustrate, if the brightness level is set to 50 on the Clarity tab, and the Brightness Out of Range threshold is set to 10 on the Warnings tab, VRS accepts any image with a brightness value from 40 to 60. (Both 40 and 60 represent a margin of error 10 for the setting at 50.) If VRS detects an image with a brightness value outside the acceptable range, it puts into effect the action selection for Brightness Out of Range, as listed on the Warnings tab.

Brightness and Contrast Visual Markers

The Clarity tab includes the following visual markers to help you identify the valid range for Brightness and Contrast:

Black Lines

The black lines indicate the baseline Brightness and Contrast values, which reflect the settings that you last applied (using the Apply Batch button).

Blue Rectangle

This box shows you the region of acceptable Brightness and Contrast values. The box is centered around the baseline settings for Brightness and Contrast, with the borders representing the Brightness and Contrast threshold values from the VRS Administration Utility dialog box. Valid settings must fall within the blue box. Invalid settings fall outside the blue box borders, and they generate warnings.

Dotted Red Lines

The dotted red lines represent the current values for Brightness and Contrast. When you have Intelligent Brightness/Contrast Adjustment enabled, the dotted red lines (along with the slider) are automatically adjusted to reflect the “intelligent” brightness and contrast values.

Gamma

Gamma correction relates to the contrast between the lightest and darkest areas of an image. You can use the slider to adjust the setting, or you can make a selection from the Gamma Correct edit box on the Clarity tab.

► To change the Clarity settings

- 1 From the VRS Interactive Properties dialog box, select the Clarity tab.
 - a **To adjust the contrast and brightness at the same time**, click within the boundaries of the brightness/contrast scale.

Click the pointer so that the intersection of the crosshairs represents the desired values for brightness and contrast. Then, a dotted line appears on the brightness/contrast scale. The horizontal dotted line represents the brightness value, and the vertical dotted line represents the contrast value.
 - b **To adjust the contrast and brightness separately**, skip to the next step.
- 2 In the Brightness box, VRS displays the current brightness setting. To change the setting, do one of the following:
 - a Click in the Brightness box, click the arrows to move through the list of settings, and click your selection.
 - b Click in the Brightness box and type in a value.
 - c Use the Brightness slider control to select a value.
- 3 In the Contrast box, VRS displays the current contrast setting. To change the setting, do one of the following:
 - a Click in the Contrast box, click the arrows to move through the list of settings, and click your selection.
 - b Click in the Contrast box and type in a value.
 - c Use the Contrast slider control to select a value.
- 4 In the Gamma Correct box, VRS displays the gamma correction setting. The correction values range from Dark to Light, with Normal at the midpoint. To change the setting, do one of the following:
 - a Click in the Gamma Correct box, click the arrows to move through the list of values, and click your selection.
 - b Click in the Gamma Correct box and type in a value.
 - c Use the Gamma slider control to select a value.

Using the Noise Tab

The Noise tab gives you a set of filters that enhance image quality and remove excessive speckling. As you adjust the Noise settings, the effects are applied to the image in the VRS Viewer window. You can fine-tune the settings until the image appearance meets your quality standards.

Note: The Noise tab settings are intended for black and white scanning; they have no effect on grayscale scanning.

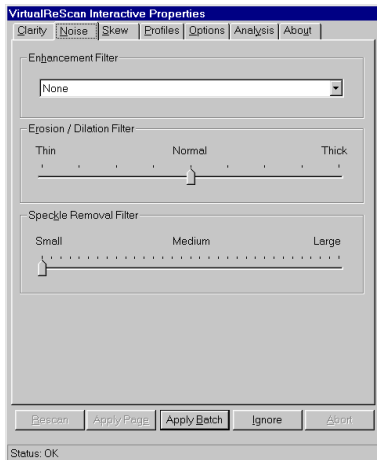

Figure 20. Noise Tab

► To change the Noise settings

- 1 From the VRS Interactive Properties dialog, select the Noise tab.
- 2 Under Enhancement Filters, you can select one of the following:
 - a None: Disables all the enhancement filters.
 - b Descreening: Activates a shade removal filter that is useful for removing halftone patterns.
 - c Image smoothing: Activates a filter that helps to smooth characters or lines that appear jagged on your image.
 - d Image cleanup: Activates a filter that smooths out characters, removes background noise, and eliminates some lines.
- 3 Use the Erosion/Dilation Slider to select the amount of thinning/thickening to apply to image elements.
 - a For image elements that are ballooned or blended together, improvement occurs as you move the slider toward the Thin setting.
 - b For image elements that are too thin or too light, improvement occurs as you move the slider toward the Thick setting.

- 4** Use the Speckle Removal Slider to remove unwanted black dots.
 - a** Move the slider toward Small if removal of small dots will achieve the desired image quality.
 - b** Move the slider toward Medium if removal of small and medium dots will achieve the desired image quality.
 - c** Move the slider toward Large if removal of small, medium, and large dots will achieve the desired image quality.

Using the Skew Tab

The Skew tab gives you settings to straighten an image that appears to be skewed, or crooked, in the VRS Viewer. To straighten an image, you rotate it up to 45 degrees clockwise, or counter-clockwise. Use the movable angle control arm to rotate the image. If necessary, you can fine-tune the rotation with the Fine Angle Adjustment slider. The Angle box on the Skew tab lists the current image angle. When the Angle box lists 0.00, the image is not skewed.

Note: The deskew process is designed to straighten an image, rather than the text on the image.

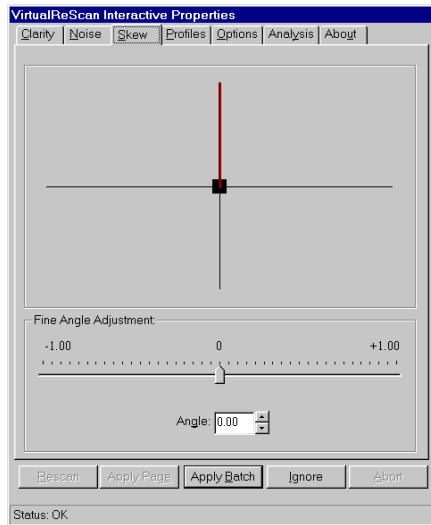

Figure 21. Skew Tab

If you want VRS automatically to correct any skewed images in a batch, select the Automatic Deskew function. See *Using the Options Tab* on page 33.

► **To change the Skew tab settings**

- 1** From the VRS Interactive Properties dialog box, select the Skew tab.
- 2** Adjust the movable angle control arm until the image is straight:
 - a** Use the mouse to select the vertical arm. When selected, the pointer changes to a hand icon.
 - b** Move the arm counter-clockwise to rotate the image to the left, or clockwise to rotate it to the right. The Angle setting changes as the image rotates; the valid range is -45 degrees to 45 degrees.
- 3** In the Angle box, you have two ways to adjust the Angle setting:
 - a** Place your cursor in the Angle box, click the arrows to review the list of settings, and click your selection.
 - b** Type a value for the correction angle directly into the Angle box.

The valid range for the angle is -45 degrees to 45 degrees.
- 4** Using the Fine Angle Adjustment Slider, you can fine-tune the deskew angle in single degree, or partial degree, increments, as follows:
 - a** By moving the slider all the way to the left, you select a complete one-degree, counter-clockwise angle adjustment.
 - b** By moving the slider all the way to the right, you select a complete one-degree, clockwise angle adjustment.
 - c** By moving the slider to a position in between the leftmost or rightmost setting, you select an angle shift that is less than a full degree. Each line on the slider scale represents 5 percent of one degree.

Using the Profiles Tab

The Profiles tab helps you set up and manage VRS image property profiles. Each profile is a user-defined combination of settings for the Clarity, Noise, and Options tabs. You can establish multiple profiles to accommodate different scanning situations, so that you don't have to repeat the process of defining image properties.

VRS uses the profile *Default settings*, unless you define and select another one. From the Profiles tab, you can define, update, load, and remove profiles.

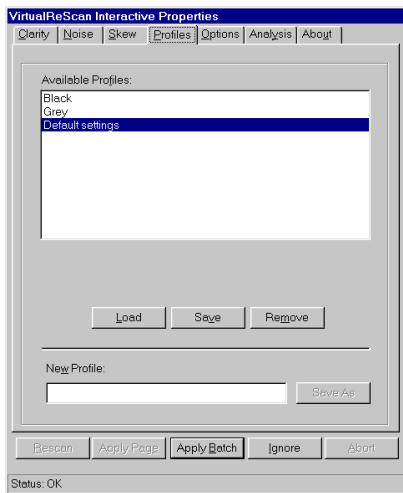

Figure 22. Profiles Tab

► To set up a profile

- 1 Open the VRS Interactive Properties dialog box and make selections from the Clarity, Noise, and Options tabs.
- 2 Select the Profiles tab.
- 3 In the New Profile text box, assign a name to the new profile. Be sure to assign a profile name with alphanumeric characters.
- 4 Select Save As. The new profile name appears in the Available Profiles list, and it becomes the active profile.

Table 4. Invalid Characters for Profile Names

Character	Description	Character	Description
:	Colon	'	Single quotation
;	Semicolon	"	Double quotation
\	Backslash	>	Greater than
/	Slash	<	Less than
	Pipe	^	Caret
&	Ampersand	.	Period
?	Question mark		

► **To change the active profile**

- 1 From the VRS Interactive Properties dialog, select the Profiles tab.
- 2 From the Available Profiles list, select the profile you want to use.
- 3 Select the Load button.

Note: If an image is open in the VRS Viewer when you change the active profile, the image is refreshed with the new settings.

or

- 1 From the VRS Interactive Properties dialog, select the Profiles tab.
- 2 From the Available Profiles list, double-click the name of the profile you want to use.

or

- 1 From the VRS menu, select the Profiles command.
- 2 When the Profiles submenu opens, select the name of the profile you want to use.

Note: If you change the active profile, it stays in effect for the current VRS session. Each time you start VRS, *Default settings* is reset as the active profile.

► **To remove a profile from the Available Profiles list:**

- 1 From the VRS Interactive Properties dialog box, select the Profiles tab.
- 2 From the Available Profiles list, select the profile(s) you want to remove.
- 3 Select Remove. The profile name clears from the Available Profiles list.

Using the Options Tab

The Options tab selections support automatic adjustments, accelerated scanning and image refresh, and assignment of optimal (or "intelligent") values for brightness and contrast. When you select a function from the Options tab, it remains in effect for the remainder of your VRS session, unless you change it again.

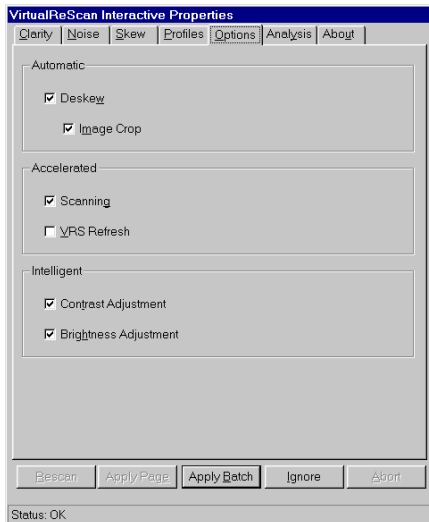

Figure 23. Options Tab

Automatic Deskew

Activates the VRS feature that automatically straightens images that are skewed when they scan. The skew is determined by the leading edge of the document.

Note: The Automatic Deskew process is page-based, rather than content-based. While VRS will automatically straighten a page, it will not straighten the data on the page (if the data was not straight on the original document).

If you prefer to correct the skew angle on an individual image basis, do not select Automatic Deskew; use the Skew tab settings instead. See the section *Using the Skew Tab* on page 29.

Image Crop

With Automatic Deskew selected, you can activate Image Crop to automatically crop any image to reflect the actual size of the scanned document. This is helpful if you scan a batch of images that consist of multiple paper sizes.

Note: If your scanning application does not support cropped images, VRS disables the Image Crop function, even if Automatic Deskew is selected.

For example, if you scan a postcard, you can enable the Image Crop feature to ensure that excess borders are removed. As a result, the image would match the actual postcard dimensions (rather than the paper size specified in the scanning application).

Accelerated Scanning

While high resolution settings have a positive impact on image quality, they can slow down the scanning process. With Accelerated Scanning in effect, VRS achieves the quality of a high resolution image without compromising speed. To maintain speed, VRS scans the image at a rate that is lower than the DPI (dots per inch) rate defined in your scanning application. Then, VRS performs an internal translation so that the image is output at the desired DPI setting.

To illustrate, suppose you select 300 DPI in your scanning application and enable Accelerated Scanning from the Options tab in VRS. As a result, the image scans at 200 DPI to maintain speed, and VRS translates it to 300 DPI to achieve the desired resolution. The table below lists the DPI settings that VRS uses for Accelerated Scanning.

Note: If you select a DPI setting of 400, VRS automatically puts Accelerated Scanning into effect.

Table 5. Accelerated Scanning DPI Settings

Your DPI Setting	Actual Scan DPI Setting	Image Output DPI Setting
400	300	400
300	200	300
240	200	240
200	200	200

VRS Refresh

To minimize the time it takes for the VRS Viewer to update an image when you apply property changes, enable the VRS Refresh function. With VRS Refresh, you ensure that VRS updates images as quickly as possible.

Intelligent Contrast Adjustment / Brightness Adjustment

With Intelligent Contrast Adjustment/Brightness Adjustment, VRS automatically selects the optimal values for contrast and brightness. This saves time and eliminates guesswork, and you achieve the best possible image quality for every page in a batch of documents.

For example, if you scan a yellow invoice and enable Intelligent Contrast Adjustment and Intelligent Brightness Adjustment, VRS automatically adjusts the contrast and brightness values to produce the best image quality for the colored sheet. When "intelligent" settings are enabled for a batch, VRS automatically applies the most accurate settings to each image in the batch. As you scan, the intelligent values for contrast and brightness are reported for each page on the Analysis tab. On the Clarity tab, the red dotted line and the slider positions are automatically updated to reflect the intelligent values detected by VRS. See the section *Using the Clarity Tab* on page 25.

► To change the selections on the Options tab

- 1 From the VRS Interactive Properties dialog box, select the Options tab.
- 2 Under Automatic, Accelerated, and Intelligent, select the options that you want to enable for the next batch scan.

Using the Analysis Tab

Use the Analysis tab to view a summary of the properties for the current image in the VRS Viewer. The summary reflects the properties at the time VRS scans the image. With the exception of the Speckle Count, none of the Analysis tab information is updated as you apply image property changes. You cannot edit the information on the Analysis tab.

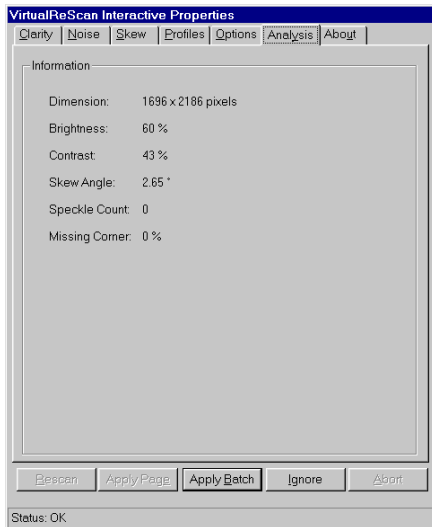

Figure 24. Analysis Tab

The information on the Analysis tab may help you identify proper threshold values for contrast and brightness on the VRS Administration Utility dialog box, as well as settings for contrast and brightness on the Clarity tab.

For example, suppose you are preparing to scan a batch of documents that have a purple background. If you are not sure how to adjust the contrast and brightness settings to achieve the best possible image quality for purple documents, scan a sample page. Then check the contrast and brightness values on the Analysis tab, because they should be close to the values that would be appropriate for the Clarity tab.

Note: If you are scanning in duplex mode, VRS evaluates only the front side of an image. Therefore, the information on the Analysis tab relates only to the front side.

If you enable the Intelligent Contrast Adjustment and/or the Intelligent Brightness Adjustment functions from the Options tab, the contrast and brightness values on the Analysis tab are automatically put into effect. With the intelligent settings enabled, VRS automatically updates the red dotted line and the sliders on the Clarity tab to reflect the contrast and brightness values listed on the Analysis tab.

Using the About Tab

The About Tab lists the VRS version information, along with the mailing address, telephone and fax numbers, web site address, and e-mail address for Kofax Image Products. For direct access to the Internet, you can do the following:

- Click the VRS Online button to visit the VRS product web site, which includes information on how to download firmware and software updates.
- Select www.kofax.com to visit the Kofax Image Products web site.
- Select www.virtualrescan.com to visit the VirtualReScan web site.



Figure 25. About Tab

Previewing Images

The preview process gives you an opportunity to test image property settings to meet quality standards. Use the Preview feature to test property settings before you scan a batch of documents, or to adjust the settings in between batches.

When you select Preview, VRS opens the most recently scanned image in the VRS Viewer. As you apply property changes from the VRS Interactive Properties dialog box, the preview image is refreshed so you can evaluate the adjustments. Be aware that the changes to the preview image are not sent to your scanning application; the image is intended only for preview purposes.

Note: The Preview function is available only if a scanned image exists in the scanner's memory.

For information on the VRS Viewer window, see the section *Using the VRS Viewer* on page 22. For information on updating image properties, see the section *Using the VRS Interactive Properties Dialog Box* on page 23.

► To preview an image

- 1 Scan a document that is similar to the document type you plan to use for batch scanning.
- 2 From the VRS menu, select Preview to display the sample image in the VRS Viewer.
When you select Preview, VRS always displays the last image scanned since the scanner was powered on (provided that such an image exists).
- 3 If desired, use the Zoom menu to adjust the magnification level.
For more information on the Zoom menu, see the section *Using the VRS Viewer* on page 22.
- 4 If necessary, use the VRS Interactive Properties dialog to change the image properties.
For more information on the VRS Interactive Properties dialog box, see the section *Using the VRS Interactive Properties Dialog Box* on page 23.
- 5 When you are satisfied with the appearance of the preview image, select the Apply Batch button in the VRS Interactive Properties dialog box.

The property settings are saved and put into effect for the next batch of scanned documents. If you expect to use the settings on a regular basis, save them as a profile, so they can be recalled as often as necessary. See the section *Using the Profiles Tab* on page 31.

Resetting VRS

The Reset command reloads the default configuration for the Adrenaline Hardware Accelerator in your PC. You should use the Reset function only if an authorized member of the Kofax technical support staff instructs you to do so.

► **To reset the VRS configuration**

- 1 From the Windows taskbar, right-click on the VRS icon to open the VRS menu.
- 2 From the VRS menu, select the Reset command.



A progress indicator appears for a few moments as the configuration is reset for the Adrenaline Hardware Accelerator.

- 3 From your scanning application, reselect the VirtualReScan Source.
- 4 Proceed with your scanning session.

Technical Support

For assistance with VirtualReScan, contact the Kofax technical support staff, as shown below. Before contacting the technical support staff, please have the following information available:

- Version of VRS you are using
- Type of hardware you are using, including your PC and any peripherals such as scanners or printers
- Type of hardware accelerator and software engine you are using
- Operating system you are using
- Description of how the problem occurred, including error message text

	Headquarters	European Headquarters
	Kofax Image Products 16245 Laguna Canyon Road Irvine, CA 92618-3603	Kofax Image Products Kranenberg 6 1731 Zellik, Brussels, Belgium
	(949) 727-1733 (voice) (949) 727-3923 (fax)	+32-2-481-6030 (Tel.) +32-2-463-1706 (Fax)
	http://www.kofax.com (Kofax Image Products home page) http://www.kofax.com/support (Kofax Technical Support page) mailto:info@kofax.com (e-mail)	

Contact Ricoh at:

	Ricoh Corporation 5 Dedrick Place West Caldwell, NJ 07006
	(800) RICOH38 (voice)
	http://www.ricoh-usa.com

Index

A

Abort button, 19
 About tab, 36
 Accelerated scanning, 24, 34
 DPI settings for, 34
 Action types
 Auto Resolve, 18
 Ignore Error, 18
 Interactive, 18
 Intervention, 18
 Return Error, 18
 Adrenaline Hardware Accelerator
 compatibility, 5
 configuring for Windows 95, 6
 configuring for Windows NT, 7
 installation, 5
 Analysis tab, 35
 Apply Batch button, 24
 Apply Page button, 24
 Auto Crop Failure error, 17
 Auto Resolve, 18
 Auto Resolve check box, 19
 Auto Resolve Manager, 19
 Automatic deskew, 24, 33
 Automatic refresh, 34

B

Blank Page warning, 15
 Brightness, 23, 25
 brightness adjustment, intelligent, 34

C

Cable, 8
 Cable Disconnect error, 17
 Clarity tab, 25
 Cleanup, image, 27
 Communication error, 17
 Configure command, 13
 Connecting PC to Scanner, 6
 Contrast, 23, 25, 26
 contrast adjustment, intelligent, 34
 Cover Open error, 17

D

descreening, 27
 Deskew angle, 23, 30

Dilation, 27
 DPI settings
 for accelerated scanning, 34

E

Erosion, 27
 Error Types
 Auto Crop, 17
 Cable disconnect, 17
 Communication, 17
 Cover open, 17
 No power, 17
 Out of Paper, 17
 Paper jam, 17
 Timeout, 17
 Errors tab, 16, 17, 18

F

Filters
 descreening, 27
 Image cleanup, 27
 image enhancement, 27
 image smoothing, 27
 Fine Angle Adjustment slider, 29
 First Time Calibration, 10

G

Gamma, 25, 26

I

Ignore button, 19
 Image cropping, 24, 33
 Image Smoothing, 27
 ImageControls, 39
 existing version, 3
 Installation, 3
 Adrenaline Hardware Accelerator, 5
 scanner cable, 8
 software, 3
 intelligent brightness adjustment, 34
 intelligent contrast adjustment, 34

M

Mode command, 13
 Mode menu, 20

N

No Power error, 17
Noise tab, 27

O

Options tab, 33
 accelerated scanning, 34
 automatic brightness adjustment, 34
 automatic contrast adjustment, 34
 automatic deskew, 33
 automatic refresh, 34
 image crop, 33
Out of Paper error, 17

P

Paper Jam error, 17
Preview command, 13
Previewing Images, 37
Product package, 2
Profile
 changing the active, 32
 default, 31
 removing a, 32
 setting up a, 31
Profile command, 13
Profiles tab, 31

R

Rescan button, 19
Reset, 38
Reset command, 13
Return Error, 18

S

Scanning source
 VirtualReScan, 9
Skew tab, 29
Software installation, 3
Speckles
 removing, 23
System Requirements, 2

T

Threshold, selecting, 15
Thresholds
 Blank Page, 15
 Brightness Out of Range, 15

 Contrast Out of Range, 15
 Missing Corner, 15
Timeout error, 17

V

VirtualReScan
 starting, 9
VRS Administration Utility dialog box, 14
 Action Options, 17
 Errors, 14
 Warnings, 14
VRS button, 19
VRS icon, 9
VRS Interactive Properties dialog box, 18, 21, 23, 24,
 26, 27, 30, 31, 32, 34, 37
 About tab, 24
 Analysis tab, 24
 buttons, 24
 Clarity tab, 23
 Noise tab, 23
 Options tab, 24
 Profiles tab, 23
 Skew tab, 23
 tab overview, 23
VRS Menu, 10, 13
 Configure, 13, 14
 Mode, 13
 Preview, 13, 21, 37
 Profile, 13
 Reset, 13, 38
VRS Online button, 36
VRS Refresh, 34
VRS Viewer, 18, 20, 21, 22, 23, 24, 27, 29, 35, 37
 using, 22
 Zoom Menu, 22

W

Warning Types
 Blank Page, 14
 Brightness Out of Range, 14
 Contrast Out of Range, 14
 Missing Corner, 14
Warnings tab, 14, 18
Web site
 VirtualReScan, 36
Windows 95, 6
Windows NT, 2, 5, 7

Z

Zoom menu, 22

